

# 2.5x2.0 SMD OSCILLATOR

## Part Number Guide

T-V-S-FF.FFFM-FS-OT-OP

**T**(Type型号): 0N=2.5×2.0×1.0mm Max ceramic osc  
**V**(Input Voltage输入电压): 1.8=1.8V 2.5=2.5V 2.85=2.85V 3=3.3V etc  
**S**(Symmetry占空比): 5=45/55 Max 6=40/60 Max  
**F**(Frequency标称频率): Normal - 5 digitals of Frequency, e.g. 8.0000M, 12.000M  
 Special - All digitals of Frequency, e.g. 13.225625M  
**FS**(Frequency Stability总频差): 50=±50 ppm, etc  
**OT**(Operating Temperature工作温度): 0070= 0°C to +70°C 4085= -40°C to +85°C, etc  
**OP**(Out put输出): 1=15PF HCMOS 2=10TTL 3=30PF 4=50PF 5=10TTL/15PF

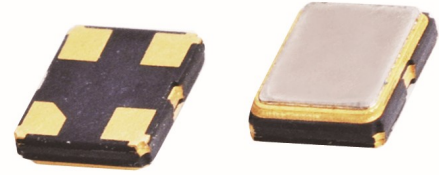

**Pb Free** **RoHS Compliant**  
 Directive 2002/95/EC

## Electrical Specifications 电气参数

Item 项目	Spec 规格		Condition 条件
Frequency Range 频率范围	0.032768MHZ 1MHZ~156.25MHZ		For further questions regarding specifications, please feel free to contact us. 对于超出标准的规格, 请联系我们
Operating Voltage 工作电压 (V)	1.8V~5.5V		
Output Waveform 输出波形	HCMOS 方波		
Output Load 输出负载	15pF		
Symmetry (Duty Cycle) 占空比 (%)	45~55		
Rise/Fall Time 上升/下降时间 (ns)	32.768KHz	<100	0.1V <sub>dd</sub> →0.9V <sub>dd</sub>
	1~10MHz	<10	
	10~40MHz	<6	
	40~156.25MHz	<3	
Current Consumption 消耗电流 (mA)	32.768KHz	<0.1	3.3V, 无负载 3.3V, No Load
	1~40MHz	<5	
	40~60MHz	<10	
	60~100MHz	<20	
	100~156.25MHz	<30	

## Mechanical Dimensions 外型尺寸

UNIT (单位): mm (毫米)

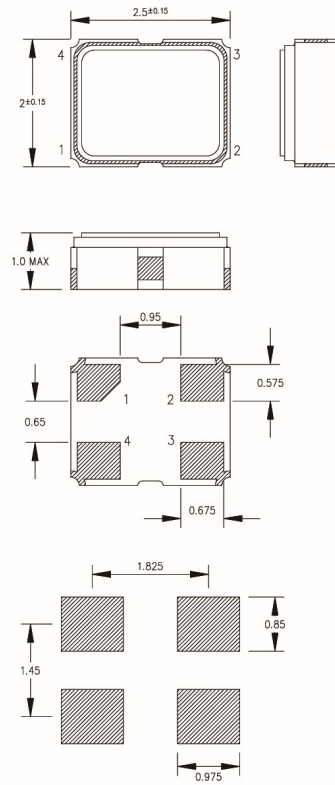

PIN	FUNCTION
1	N/C or Tri-state
2	Ground
3	Output
4	V <sub>dd</sub>